

CONNECTED ROLL'SERVICE

Heated temperature holding banquet trolley



HOT CONNECTION 



Traceability

Easy handling

Compact

Hygiene

Connected

Easy to load

Features a fast rise in temperature feature, from 20 to 85°C in 20 minutes.

Mobile temperature-controlled cabinets. Food-grade stainless steel construction. Rock wool insulation in walls and door. Integrated touch-sensitive control panel. Fully shelved interior with stamped bottom and runners. Space between runners: 71 mm. Solid Stainless steel or glass door, 270° opening with compressible seal. 2 side handles and a guide bar at the rear.

Door locking system in the open position.

New: you can change the door opening direction yourself to suit your kitchen layout. Condensate collection pan on all models except the 5-level ones.

Non-marking shockproof perimeter strip, except for the 5-level model equipped with corner bumpers. 4 swivel castors, 2 of which have brakes, Ø 160 mm with stainless steel cap on GN 2/1 cabinets with 20 levels, Ø 125 mm with polyamide cap on GN 2/1 cabinets with 10 and 15 levels, GN 1/1 cabinets with 10, 15 and 20 levels, and Ø 80 mm with Stainless steel caps on 5-level cabinets. IP 25 protection rating, allowing low-pressure jet cleaning. NF Food Hygiene certification.

Electric heating system: rear centrifugal fan with external motor

determining the passage of air through sealed stainless steel armoured heating elements. Stainless steel air duct and diffuser. Temperature preset to 85°C. Rapid temperature rise: from 20 to 85°C in 20 minutes. Spiral cord with moulded plug for electrical connection, voltage 230V, frequency 50/60 Hz. New: touch control panel for traceability management through temperature recording in the chamber. Data can be retrieved in Excel format via a USB port on the control panel.

Electricity consumption is also recorded.

LONGTIME® certification.

How many portions* ?

Stainless steel pans	Capacity (Litres)	Number of servings*
GN 1/1 depth 55 mm	7,5	24-30 meats or 17-20 vegetables
GN 1/1 depth 65 mm	8,5	27-34 meats or 20-26 vegetables
GN 1/1 depth 100mm	13	47-56 meats or 34-41 vegetables
GN 1/1 depth 150 mm	20	75-85 meats or 54-63 vegetables

*Average weight of a portion : meat 100 to 120g. Vegetables 150 to 180g



Control panel with humidification



Control panel without humidification

25 avenue Jean Moulin - CS2005
71700 TOURNUS - FRANCE
RC Mâcon B 383 567 104
Code APE 295 E
SAS Capital 16 355 625€

FRANCE
Tél : 03 85 27 42 00
E-mail : commercial@tournus.com

EXPORT
Tél : + 33 (0)3 85 27 42 65
E-mail : export@tournus.com

ROLL'SERVICE WITH HUMIDIFICATION CONTROL



The electronic control allows selection of 5 rates of hygrometry. Removable rotomoulded tank accessible from the front, with 2 litre capacity, allowing 24 hour operation.

Condensate drip system
*except for the 5 level Roll'Service

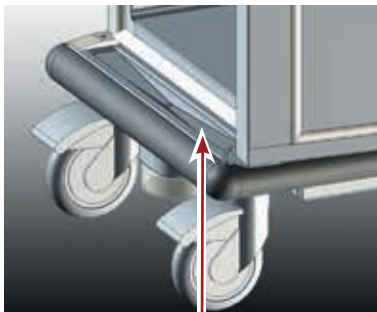

Embossed chute

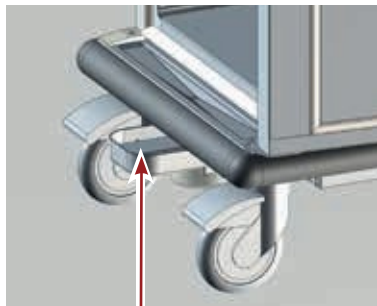

Removable and retractable condensate drip system

Roll'Service GN 1/1

Roll'Service	Electrical consumption (kWh) (1)	Input power (kW) (2)	Capacity (litres)	Overall dim. l x W x h (mm)	Reference
10 levels with s/steel door	0,29	0,825	146	528 × 821 × 1134	507 336
15 levels with s/steel door	0,30	1,215	215	528 × 821 × 1489	507 356
15 levels with glass door	0,30	1,215	215	528 × 821 × 1489	507 357
20 levels with s/steel door	0,575	1,215	284	528 × 821 × 1844	507 386
20 levels with glass door	0,575	1,215	284	528 × 821 × 1844	507 387

Roll'Service GN 2/1

Roll'Service	Electrical consumption (kWh) (1)	Input power (kW) (2)	Capacity (litres)	Overall dim. l x W x h (mm)	Reference
10 niveaux porte inox	0,410	1,215	285	733 × 941 × 1134	507 436
15 niveaux porte inox	0,405	1,215	420	733 × 941 × 1489	507 456
15 niveaux porte vitrée	0,405	1,215	420	733 × 941 × 1489	507 457
20 niveaux porte inox	0,785	2,015	555	733 × 941 × 1880	507 486
20 niveaux porte vitrée	0,785	2,015	555	733 × 941 × 1880	507 487

(1) Corresponds to the average hourly power consumption according to standard NF 040-016 for a 3.5-hour cycle.

(2) Corresponds to the maximum power at start-up, which determines the size of the electrical connection.



NEW: Touch controls



ROLL'SERVICE WITHOUT HUMIDIFICATION



Roll'Service GN 1/1

Roll'Service	Electrical consumption (kWh/h) (1)	Input power (kW) (2)	Capacity (litres)	Overall dim. l x W x h (mm)	Reference
5 levels with s/steel door	0,22	0,825	77	524 × 817 × 708	507 301
10 levels with s/steel door	0,29	0,825	146	528 × 821 × 1134	507 331
15 levels with s/steel door	0,30	1,215	215	528 × 821 × 1489	507 351
15 levels with glass door	0,30	1,215	215	528 × 821 × 1489	507 352
20 levels with s/steel door	0,575	1,215	284	528 × 821 × 1844	507 381
20 levels with glass door	0,575	1,215	284	528 × 821 × 1844	507 382

507 352

Roll'Service GN 2/1

Roll'Service	Electrical consumption (kWh/h) (1)	Input power (kW) (2)	Capacity (litres)	Overall dim. l x W x h (mm)	Reference
10 levels with s/steel door	0,410	1,215	285	733 × 941 × 1134	507 431
15 levels with s/steel door	0,405	1,215	420	733 × 941 × 1489	507 451
15 levels with glass door	0,405	1,215	420	733 × 941 × 1489	507 452
20 levels with s/steel door	0,785	2,015	555	733 × 941 × 1880	507 481
20 levels with glass door	0,785	2,015	555	733 × 941 × 1880	507 482

(1) Corresponds to the average hourly power consumption according to standard NF 040-016 for a 3.5-hour cycle.

(2) Corresponds to the maximum power at start-up, which determines the size of the electrical connection.



Option :
Lock and key

507 481

Options

Description	Reference
Extra-cost for lock and key	701 961
Extra-cost for 4 swivel stainless steel wheels Ø 120 mm including 2 brakes to replae wheels with polyamid cover	702 190



507 301



507 431



507 452