

# YOUR CUSTOMISED PROJECTS

YOU IMAGINE...  
WE BUILD

**TOURNUS**  
**EQUIPEMENT**

FRENCH MANUFACTURER FOR THE CATERING INDUSTRY



## TECHNICAL EXPERTISE

- A dedicated team supports you throughout the entire project process.
- Discussions about your needs, feasibility studies, costing, creation of detailed specifications, layout plans, factory production, site supervision, after-sales service... We are here to answer all your questions.

### THE ADVANTAGES

All equipment is assembled 'dry' at the factory.

This ensures that the line complies with the order and that assembly can be carried out quickly and without surprises.

## THE STAGES OF THE BESPOKE PROJECT

### 1- Detailed notebook

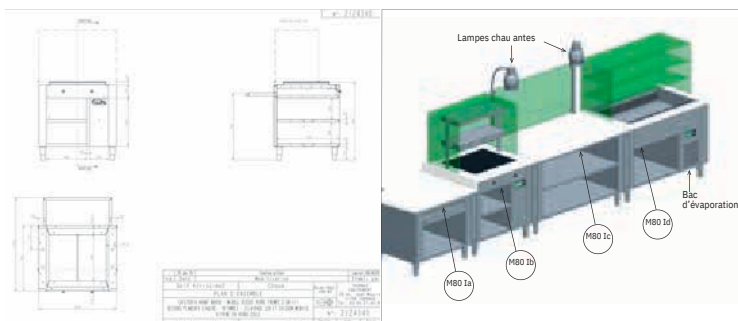

### 2- Manufacturing plan

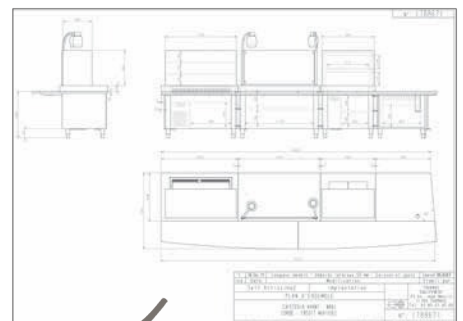

### 4 - Final installation



### 3- Manufacturing



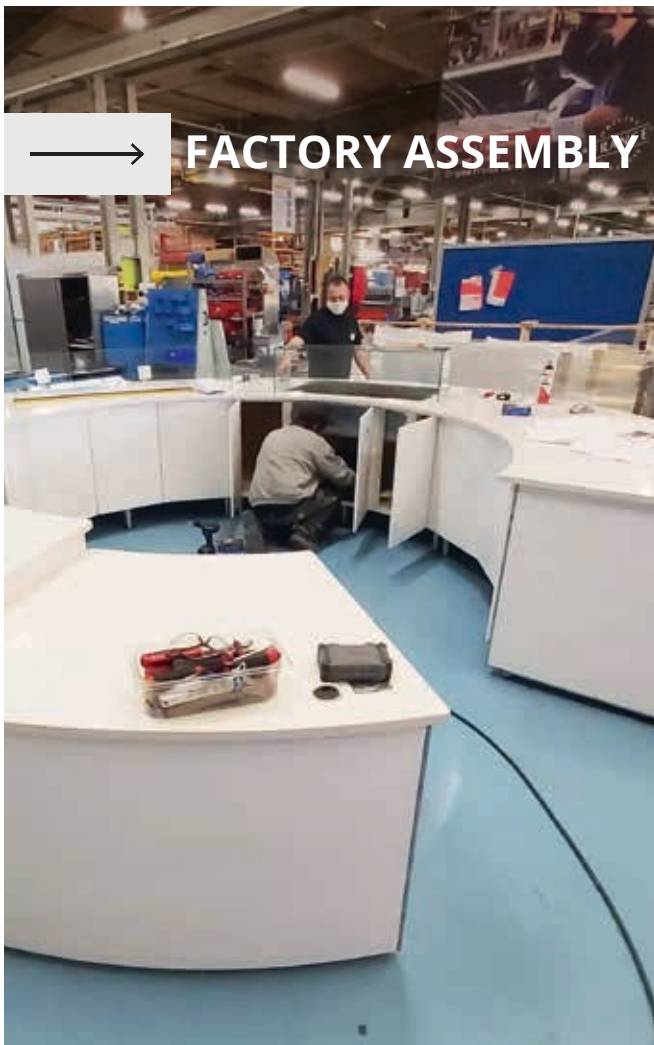

→ **FACTORY ASSEMBLY**

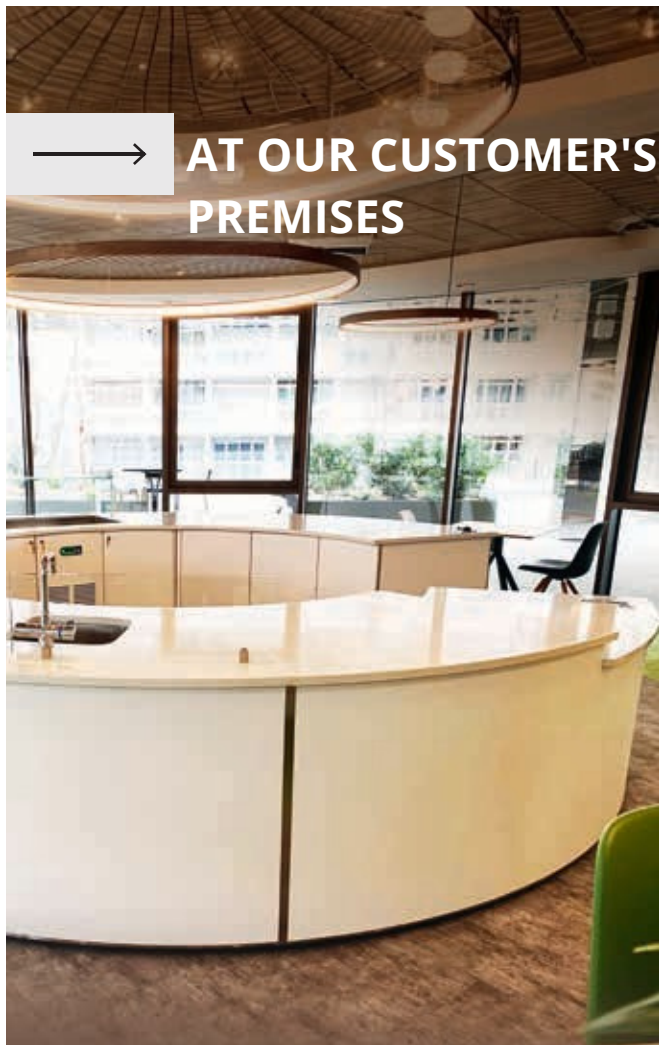

→ **AT OUR CUSTOMER'S PREMISES**

To bring your project to life, we offer you the most daring solutions: shapes, volumes and a variety of materials (Stainless steel, wood, granite, quartz, Dekton, glass, etc.).

The wide variety of combinations is achieved through different line layouts, cladding and recesses: the façades are made according to your ideas, in laminate, solid wood, Stainless steel, etc., and their brilliance is enhanced by varied and original lighting.

### THE ADVANTAGES **+**

**Show cooking or a combination of several themes within the same space, installation in a shop or in a scramble...**

**The equipment can also be integrated into all the designs created by decorators and made to measure by carpenters or interior designers.**





### Refrigerated area

- Semicircular end unit
- Refrigerated quartz top
- Distribution display unit
- Ventilated tank unit
- Beverage unit

- Quartz top with sliding rails
- LED lighting under the ramp



QUARTZ TOP



GATE FOR TECHNICAL ACCESS



### Starters station - Vegetable station - Dessert station

Refrigerated areas and invisible induction hobs (under-counter installation). Built-in storage niches.

# EVEN MORE REFERENCES...

- Accor
- Adéo Ronchin
- Airbus
- Aircelle
- Alstom
- In Sénégal
- Azalaï Hotels
- Beachcomber
- Training centre  
«All in tennis Academy »
- State Administrative  
Centre in Lyon
- Crédit Agricole Amiens
- Eko Hôtel
- Groupe Roullier
- Hôpital Nord-Franche-  
Comté
- Hôtel Marriott
- The Kaïla
- Ritz Intercontinental
- Paprec Energies Réseau
- Park Inn
- Pullman
- Radisson
- ONU's restaurant
- Royal Zanzibar Beach  
Resort
- Terrou Bi

## Contact us

Meet our team to discuss your project and learn about how our factory is organised.

### Ludovic Cardinal

Selfs Project Manager

Tél : 06 47 15 59 04

lcardinal@tournus.com

### Claude Philippe

Selfs Project Manager

Tél : 07 87 23 71 64

cphilippe@tournus.com