

The CHR furniture range is designed for use in small communal settings and restaurants. Offering high quality and prices in line with Tournus standards, it is made entirely from stainless steel sheet metal. This range is limited in terms of dimensions and is not available as a made-to-order product.

CATERING TABLES

Stainless steel worktop, 12/10 mm thick, backed with a water-repellent laminate panel and reinforced with a profiled frame. 40 mm high skirting and 100 mm high backsplash with straight edges. Stainless steel legs, Ø 38 mm, set back 65 mm at the rear on tables with a backsplash and 55 mm on central tables. Adjustable levelling feet. Height 900 mm (+0/30 mm). Crushed folds on the worktop, backsplash and shelf. Delivered flat-packed in plastic film. Very quick assembly via interlocking joints.



503 201



503 204



523 264



503 304

Tables with legs

Overall dim. W x L (mm)	Central Ref.	Central with shelf Ref.	With upstand Ref.	With upstand and shelf Ref.
700 x 700	503 201	503 241	–	–
700 x 1000	503 202	503 242	503 222	503 262
700 x 1200	503 203	503 243	503 223	503 263
700 x 1400	503 204	503 244	503 224	503 264
700 x 1600	503 206	503 246	503 226	503 266
700 x 1800	503 207	503 247	503 227	503 267
700 x 2000	503 209	503 249	503 229	503 269

Tables on wheels

4 swivel wheels Ø 125 mm with polyamide cover including 2 brakes.

Overall dim. WxL (mm)	Central Ref.	Central with shelf Ref.	With upstand Ref.	With upstand and shelf Ref.
700 x 1000	523 202	523 242	523 222	523 262
700 x 1200	523 203	523 243	523 223	523 263
700 x 1400	523 204	523 244	523 224	523 264
700 x 1600	523 206	523 246	523 226	523 266
700 x 1800	523 207	523 247	523 227	523 267
700 x 2000	523 209	523 249	523 229	523 269

Catering chef's tables without tap

Chef's tables without tap	Overall (mm)	With upstand Ref.	With upstand and shelf Ref.
Left sink	700 x 1200	503 283	503 303
Left sink	700 x 1400	503 284	503 304
Left sink	700 x 1600	503 286	503 306
Right sink	700 x 1200	503 323	503 343
Right sink	700 x 1400	503 324	503 344
Right sink	700 x 1600	503 326	503 346

Catering chef's table with tap

Mixer tap, ref. 230 300, 15x21, 30l/mn



Chef's tables with tap	Overall dim. Wxl (mm)	With upstand Ref.	With upstand + undershelf Ref.
Left sink	700 × 1200	<u>503 293</u>	<u>503 313</u>
Left sink	700 × 1400	<u>503 294</u>	<u>503 314</u>
Left sink	700 × 1600	<u>503 296</u>	<u>503 316</u>
Right sink	700 × 1200	<u>503 333</u>	<u>503 353</u>
Right sink	700 × 1400	<u>503 334</u>	<u>503 354</u>
Right sink	700 × 1600	<u>503 336</u>	<u>503 356</u>



503 521

Options for catering tables

Description	Reference
Drawer with panel + polypropylene tray	<u>503 521</u>



CATERING SINK

Stainless steel construction, height 900 mm. Front edge height 40 mm. Folded upstand height 100 mm. Legs Ø 38 mm with jack, 80 mm indent at rear. Grooved draining boards, anti-drip edges. Soundproofed basins and draining boards. Delivered flat packed in carton.









503 611

Catering sinks - basins 400 x 500 mm

Description	Overall dim. Wxl (mm)	Without tap Ref.	With tap (ref. 230 300) Ref.
2 basins + right draining board 	700 × 1600	503 601	503 611



Catering sinks - basins 600 x 500 mm

Description	Overall dim. Wxl (mm)	Without tap Ref.	With tap (ref. 230 300) Ref.
1 basin 	700 × 800	503 602	503 612
1 basin + right draining board 	700 × 1400	503 603	503 613
1 basin + left draining board 	700 × 1400	503 609	503 619
2 basins 	700 × 1400	503 606	503 616
2 basins + right draining board 	700 x 1900	503 607	503 617
2 basins + left draining board 	700 x 1900	503 608	503 618



503 614

Catering sinks for dishwasher

Description	Overall dim. Wxl (mm)	Without tap Réf.	With tap (ref. 230 300) Ref.
1 basin 500x500 + right draining board 	700 × 1200	503 610	503 620
1 basin 500x500 + left draining board 	700 × 1200	503 605	503 615
2 basins 400 x 500 + left draining board 	700 × 1600	503 604	503 614





Catering sinks - basins 400 x 500 + shelf

Description	Overall dim. Wxl (mm)	Without tap Ref.	With tap (ref. 230 300) Ref.
2 basins + right draining board 	700 × 1600	503 621	503 631

Catering sinks - basins 600 x 500 + shelf



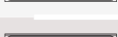

503 633

Description	Overall dim. WxL (mm)	Without tap	With tap (ref. 230 300)
		Ref.	Ref.
1 basin 	700 × 800	503 622	503 632
1 basin + right draining board 	700 × 1400	503 623	503 633
1 basin + left draining board 	700 × 1400	503 629	503 639
2 basins 	700 × 1400	503 636	503 636
2 basins + right draining board 	700 × 1900	503 627	503 637
2 basins + left draining board 	700 × 1900	503 628	503 638



503 635

Catering sinks for dishwasher + shelf

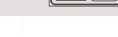
Description	Overall dim. WxL (mm)	Without tap	With tap (ref. 230 300)
		Ref.	Ref.
1 basin 500x500 + right draining board 	700 × 1200	503 630	503 640
1 basin 500x500 + left draining board 	700 × 1200	503 625	503 635
2 basins 400x500 + left draining board 	700 × 1600	503 624	503 634

CATERING WALL CABINET

Stainless steel construction. Height 600 mm. Adjustable middle shelf. Reinforced sliding doors, suspended from a rail fixed to the upper part, with stop-blocks. Flattened folds used throughout on the front edge, shelf, handles and floor. Fixed to wall using 2 supports.



503 554



Containers on slide bars bottom parts

Description	Dimensions Wxl (mm)	Reference
Catering wall cabinet	400 × 1000	<u>503 552</u>
Catering wall cabinet	400 × 1200	<u>503 553</u>
Catering wall cabinet	400 × 1400	<u>503 554</u>
Catering wall cabinet	400 × 1600	<u>503 555</u>
Catering wall cabinet + 5s/s GN containers*	400 × 1800	<u>503 557</u>
Catering wall cabinet + 4 s/s GN containers*	400 × 1000	<u>503 562</u>
Catering wall cabinet + 7 s/s GN containers*	400 × 1200	<u>503 563</u>
Catering wall cabinet + 7 s/s GN containers*	400 × 1400	<u>503 564</u>
Catering wall cabinet + 9 s/s GN containers*	400 × 1600	<u>503 565</u>
Catering wall cabinet + 9 s/s GN containers*	400 × 1800	<u>503 567</u>

* containers GN 1/3, depth 100 mm
Extra cost for lock and key (ready to assembly) - Ref 118 882

CATERING HIGH CUPBOARD

Stainless steel construction, height 1800 mm. Reinforced sliding doors, suspended from a rail fixed on the upper part, with stop-blocks. Horizontal top. 3 adjustable shelves. Polyamide leg with jacks with no exposed thread. Flattened folds used throughout on the front edge, shelves, handles and floor.



503 493

Description	Dimensions Wxl (mm)	Reference
High cupboard with sliding doors	600 x 1000	<u>503 492</u>
High cupboard with sliding doors	600 x 1200	<u>503 493</u>

Option : Key lock for wall cabinets, units and tall cabinets, Ref. : 118 882

CATERING CUPBOARD FOR CLEANING PRODUCTS

Stainless steel construction, height 1800 mm. Reinforced 1 or 2 hinged doors with key. Horizontal top. Vertical separation. 3 adjustable half shelves + 1 lower fixed shelf. Polyamide leg.



Description	Dimensions Wxl (mm)	Reference
Cupboard 1 door with vertical separation	500 x 600	<u>503 481</u>
Cupboard 2 doors with vertical separation	500 x 1000	<u>503 482</u>
Additional shelf 1 door		<u>121 989</u>
Additional shelf 2 doors		<u>121 990</u>

CATERING UNITS

Stainless steel construction, height 900 mm (+0/65 mm). Top surface lined with water repellent laminated panel. Folded upstand height 100 mm. Front strip height 40 mm. Adjustable middle shelf. Reinforced sliding doors, suspended from a rail fixed on the upper aprt, with stop-blocks. Polyamide legs, with jacks with no exposed thread. Flattened folds used throughout on the front edge, the upstand, shelf, handles and floor.



503 503

Description	Dimensions Wxl (mm)	Units on feet	Units on wheels
		Ref	Ref
Catering unit+upstand with sliding doors	700 x 1000	<u>503 502</u>	<u>523 502</u>
Catering unit+upstand with sliding doors	700 x 1200	<u>503 503</u>	<u>523 503</u>
Catering unit+upstand with sliding doors	700 x 1400	<u>503 504</u>	<u>523 504</u>
Catering unit+upstand with sliding doors	700 x 1600	<u>503 506</u>	<u>523 506</u>
Catering unit+upstand with sliding doors	700 x 1800	<u>503 507</u>	<u>523 507</u>

Option : Key lock for wall cabinets, units and tall cabinets, Ref. : 118 882

CATERING WALL SHELVES

Stainless steel construction. Shelves with tray, thickness 1,2 mm. Rear upstand 400 mm high, recessed by 40 mm. Useful depth 360 mm for shelf width 400 mm and width 260 mm for shelf width 300 mm. Load : 100 kg distributed (according to the type of wall). Wall fixation by means of 4 screws. Shelves with GN pans : monobloc support to screw under the shelf, stainless steel GN pans ½ depth 100 mm supplied.



503 442



503 452

Description	Overall dim. Wxl (mm)	Shelves with tray	Shelves with tray with GN containers	
		Ref.	Ref.	Number
Catering wall shelf	300 × 600	503 429	-	-
Catering wall shelf	300 × 800	503 430	-	-
Catering wall shelf	400 × 1000	503 441	503 451	4
Catering wall shelf	400 × 1200	503 442	503 452	5
Catering wall shelf	400 × 1400	503 443	503 453	6
Catering wall shelf	400 × 1600	503 444	503 454	7

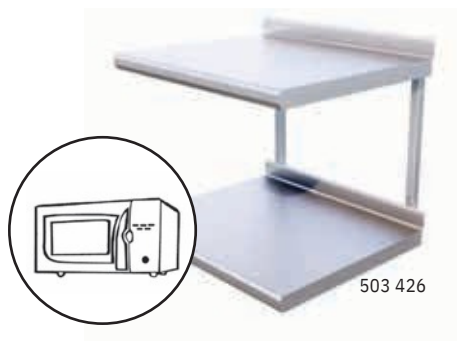

503 426

Description	Dimensions W × l (mm)	Reference
Shelves for microwave ovens, 1 level	500 × 600	503 425
Shelves for microwave ovens, 2 levels	500 × 600	503 426
Salamander grill shelf	478 × 600	503 415

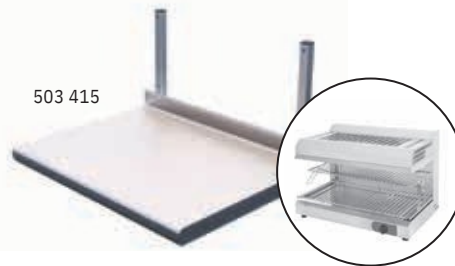

503 415

WALL SUPPORT

Wall support for 3 GN pans. Delivered with 3 separation bars to transform the product into a support for 6 GN 1/6 pans. Height 200 mm. Wall fixing by screws. Pans not delivered.

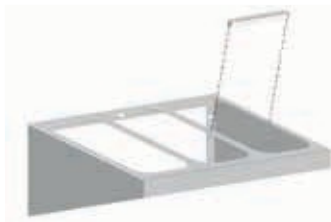

Description	Dimensions W × l (mm)	Reference
Wall support for 3 GN 1/3 pans	350 × 560	503 420

